

## ■ INT-DO-32R-F Interface Unit

32 channels - isolated discrete output with fuse and electromechanical or solid state relays

### Description :

The **INT-DO-32R-F** interface unit enables to connect up to 32 discrete outputs to a digital control system or a programmable logic controller. The control signals are connected to the DCS or the PLC either by a SUBD 37 pins connector to a 32 channels DO card, or by HE10-10 pins connectors and flat cables to several 8 channels DO cards (up to 4). Each signal controls a removable 24Vdc relay in order to drive a motor, a valve or a solenoid. Each channel is protected by a fuse. The N.O contacts available on terminals TB1 are polarized by group of 16 channels. TB3 and TB4 terminals are used to power the relay contacts (24Vdc or 48Vdc or up to 250Vac). A yellow LED indicates the status of each channel

### Product options :

Option **ST**: INT-DO-32R-F-ST (Load connected using Screw Terminals)  
 Option **ST2.5**: INT-DO-32R-F-ST2.5 (Load connected using Screw Terminals with capacity of 24 to 14AWG (0.22 to 2.5mm<sup>2</sup>))  
 Option **CCT**: INT-DO-32R-F-CCT (Load connected using Cage Clamp Terminals)  
 Option **STD, COR, SLD, SLA**: INT-DO-32R-F-ST-STD or other Relays option. Refer to page 2 and 3 to chose the right option.

Fuse value in standard are given below. For a special value, please consult us



### Technical specifications :

#### Dimensions:

Wide : 125 mm  
 Length : 240mm  
 Depth : 65mm

#### Weight:

700 g

#### Mounting:

Asymmetric or symmetric DIN rail

#### Terminal conductor section:

TB1: ST or CCT 26 to 16AWG  
 ( 0.14 to 1.5mm<sup>2</sup>)  
 TB3 & TB4: 24 to 10AWG  
 ( 0.2 to 4mm<sup>2</sup>)  
 TB2 (option) 26 to 16AWG  
 ( 0.14 to 1.5mm<sup>2</sup>)

#### Temperature range:

Operating : -10°C to 60°C  
 Storage: -20°C to 60°C

#### Humidity:

Up to 90% (no condensation)

#### Insulation voltage:

1500 vac between input (control signal) and output (contacts)

#### Fuse protection:

16A 250Vac 5 x 20 , for the contacts  
 Power supply ( group of 16 channels)  
 5 A 250Vac for each channel with electromechanical relay  
 2A 250Vac for each channel with Solid state relays

#### Connection to the DCS or to the PLC:

##### To several 8-channel DO cards:

Four HE10-10 pin male connectors with locks for female connector, central polarization and strain relief.

##### To one 32-channel DO card:

One Sub-D 37 pin male connector with UNC 4-40 female lock.  
 One screw terminal TB2 (-) allows an optional connection to the 24vdc power supply return (-) of the DCS or PLC.  
 One screw for the shield connection.

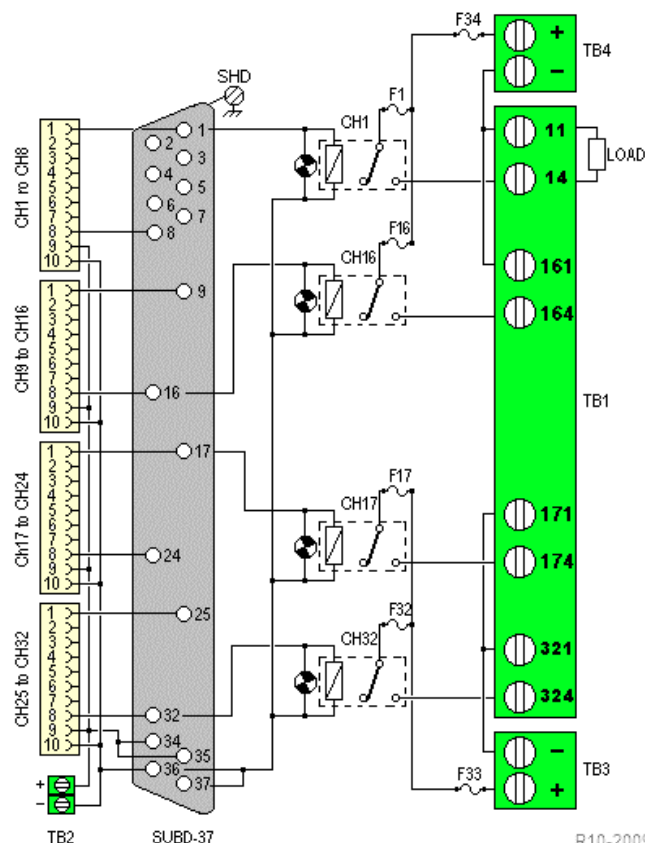

R10-2009

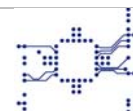

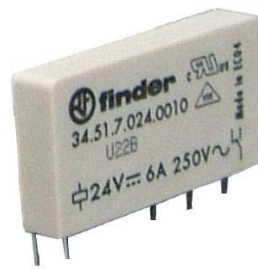
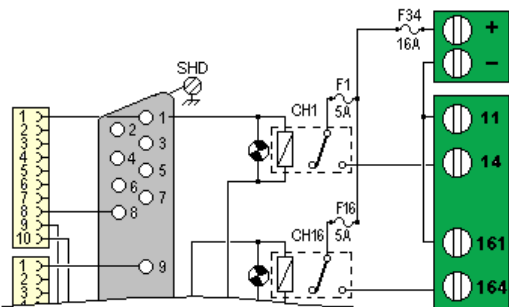

TYPE	ELECTROMECHANICAL RELAY	ELECTROMECHANICAL RELAY
REFERENCE	REL24-STD-945144	REL24-COR-945147 (Gold contacts)
<b>General characteristics</b>		
Mechanical expected life	10.000.000 operations	10.000.000 operations
Expected life at max load	60000 Operations	60000 Operations
Operate time / release time / debounce	5 ms / 3 ms / 5 ms	5 ms / 3 ms / 5 ms
Initial breakdown voltage		
Coil / contact	4000 Vac .	4000 Vac .
Contact O / Contact C	1000 Vac .	1000Vca .
Ambient temperature	-40°C to 85°C	-40°C to 85°C
Initial insulation resistance	1000 Mohms	1000 Mohms
Protection	IP67	IP67
Dimensions	W : 6mm / L : 29mm / H : 17mm	W : 6mm / L : 29mm / H : 17mm
<b>Coil characteristics :</b>		
Nominal voltage	24Vcc	24Vcc
Voltage operating range	17 - 48Vdc	17 - 48Vdc
Pick-up voltage	16,8Vdc	16,8Vdc.
Drop-out voltage	1,2Vdc	1,2Vdc
Nominal operating current	7,1 mA	7,1 mA.
Coil resistance	3250 ohms +/-10%	3250 ohms +/-10%
Nominal power	0,2W to 24Vdc	0,2W to 24Vdc
<b>Contacts characteristics :</b>		
Contact material	AgSnO2	AgSnO2 gold plated.
Arrangement	3 poles contact	3 poles contact
Switching characteristics (resistive load)		
Nominal current	6 A ( 250 Vac , 30Vdc) .	6 A ( 250 Vac , 30Vdc).
Nominal voltage	250 Vac .	250 Vac .
Minimum load	500 mW ( 12Vcc / >10mA )	400 mW / 5Vcc / 5mA
Switching power in DC	6A ( 30V). 0,5A (48V).0,15A (220V)	6A ( 30V). 0,5A (48V).0,15A (220V)
Switching power in AC	6A (250V)	6A (250V)

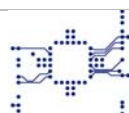

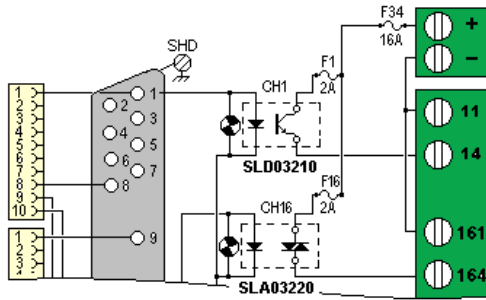

TYPE	DC SOLID STATE RELAY	AC SOLID STATE RELAY
REFERENCE	SLD03210-945148	SLA03220-945150
<b>General characteristics</b>		
Operating temperature range	-20 / +80°C	-20 / +80°C
Storage temperature range	-25 / +80°C	-40 / +100°C
Input-Output isolation	2500 VRMS	4000 VRMS
Weight	8g	8g
Conformity	EN60947-5-1	EN60947-5-1
Approved	UL pending	UL pending VDE0805(EN60950)
<b>Control characteristics</b>		
Control voltage	Min:18Vdc Nom:24Vdc Max:32Vdc	Min:18Vdc Nom:24Vdc Max:32Vdc
Control current @ Uc nom	Min:5.5mA Nom:7.7mA Max:10.2mA	Min:5.6mA Nom:7.7mA Max:10.2mA
Release voltage	Max :8.3Vdc	Max :1Vdc
Internal resistance	3000 ohms	3000 ohms
<b>Output characteristics</b>		
Load voltage	Typical : 48Vdc	Typical : 230Vrms
Voltage operating range	0-60Vdc	12-275Vrms
Nominal current	2.5A	2A rms
Non repetitive overload current	6A	80A
On state voltage drop	0.4Vdc @ 2A	1.2V @ II nom
Static output On resistance	200 mOhms	
Off State leakage current	< 1mA	< 1.5mA
Minimum load current	1mA	5mA
Turn On time	50 µs	10 µs
Turn Off time	600µs	10ms
Operating switching frequency	10 Hz	47 Hz to 400 Hz (range)
Transient voltage suppressor	Yes	Yes
Peak power dissipation	600W	
Peak voltage (clamping voltage)	60vdc	600Vac
Synchronizing level		25Vac
Latching voltage		5Vac
Off State Dv / Dt		500V/µs
Max non repetitive Di / Dt max		100A/µs
Snubber		10nF 100ohms

