

■ INT-DO-16R-1 Interface Unit

16 channels - isolated discrete output with electromechanical or solid state relays

Description :

The **INT-DO-16R-1** interface unit enables to connect up to 16 discrete outputs to a digital control system or a programmable logic controller. The control signals are connected to the 16 channel I/O card of a DCS or a PLC using a SUBD25 pin male connector. Each signal controls a 24Vdc relay in order to drive a motor, a valve or a solenoid. Each relay is replaceable and has a 3 pole contact (only electromechanical relay). A yellow LED indicates the status of each channel.

Product options :

- Option **ST**: INT-DO-16R-1-ST (Load connected using Screw Terminals)
- Option **ST2.5**: INT-DO-16R-1-ST2.5 (Load connected using Screw Terminals with capacity of 24 to 14AWG (0.22 to 2.5mm²))
- Option **CCT**: INT-DO-16R-1-CCT (Load connected using Cage Clamp Terminals)
- Option **STD, COR, SLD, SLA**: INT-DO-16R-1-ST-STD or other Relays option. Refer to page 2 and 3 to chose the right option.



Technical specifications :

Dimensions:		Maximum current:	
Wide : 125 mm		5A per channel	
Length : 185mm		Temperature range:	
Depth : 70 mm		Operating : -10°C to 60°C	
Weight:		Storage: -20°C to 60°C	
450 g		Humidity:	
Mounting:		Up to 90% (no condensation)	
Asymmetric or symmetric DIN rail		Insulation voltage:	
Conductors section:		1500 vac between input (control signal) and output (contacts), and	
ST : Screw Terminals: 26 to 16AWG		1000 vac between NO and NC terminals.	
(0.14 to 1.5mm ²)			
CCT : Cage Clamp Terminals or			
spring terminals: 26 to 16AWG			
(0.14 to 1.5mm ²)			
Connection to the DCS or to the PLC:			
One Sub-D 25 pin male connector with UNC 4-40 female lock.			
One M3 screw for the shield connection.			
Relays to be plugged:			
Electromechanical or solid state relays can be plugged and mixed on the same interface unit.			
See the characteristics on sheet 2 and 3.			

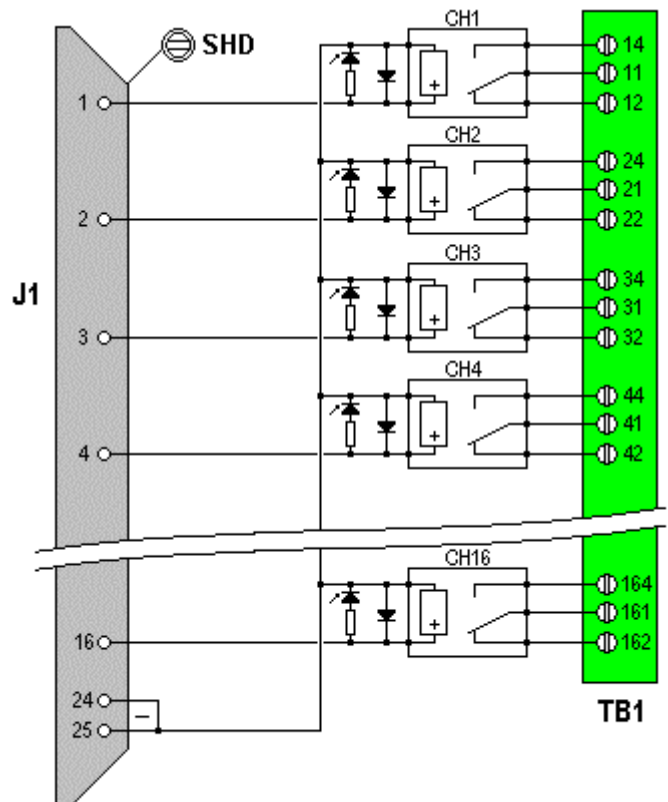

R10-2009

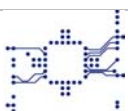

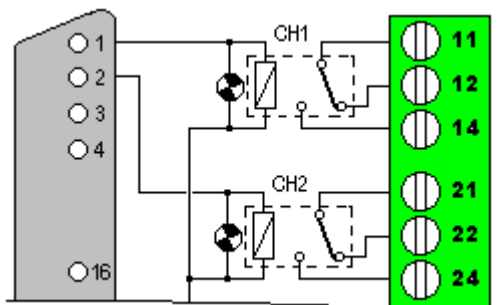

TYPE	ELECTROMECHANICAL RELAY	ELECTROMECHANICAL RELAY
REFERENCE	REL24-STD-945144	REL24-COR-945147 (Gold contacts)

General characteristics		
Mechanical expected life	10.000.000 operations	10.000.000 operations
Expected life at max load	60000 Operations	60000 Operations
Operate time / release time / debounce	5 ms / 3 ms / 5 ms	5 ms / 3 ms / 5 ms
Initial breakdown voltage		
Coil / contact	4000 Vac .	4000 Vac .
Contact O / Contact C	1000 Vac .	1000Vca .
Ambient temperature	-40°C to 85°C	-40°C to 85°C
Initial insulation resistance	1000 Mohms	1000 Mohms
Protection	IP67	IP67
Dimensions	W : 6mm / L : 29mm / H : 17mm	W : 6mm / L : 29mm / H : 17mm

Coil characteristics :		
Nominal voltage	24Vcc	24Vcc
Voltage operating range	17 - 48Vdc	17 - 48Vdc
Pick-up voltage	16,8Vdc	16,8Vdc.
Drop-out voltage	1,2Vdc	1,2Vdc
Nominal operating current	7,1 mA	7,1 mA.
Coil resistance	3250 ohms +/-10%	3250 ohms +/-10%
Nominal power	0,2W to 24Vdc	0,2W to 24Vdc

Contacts characteristics :		
Contact material	AgSnO2	AgSnO2 gold plated.
Arrangement	3 poles contact	3 poles contact
Switching characteristics (resistive load)		
Nominal current	6 A (250 Vac , 30Vdc)	6 A (250 Vac , 30Vdc).
Nominal voltage	250 Vac	250 Vac
Minimum load	500 mW (12Vdc / >10mA)	500 mW / 5Vdc / 5mA
Switching power in DC	6A (30V). 0,5A (48V).0,15A (220V)	6A (30V). 0,5A (48V).0,15A (220V)
Switching power in AC	6A (250V)	6A (250V)

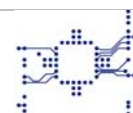

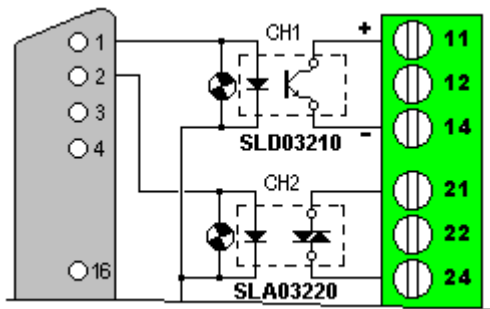

TYPE	DC SOLID STATE RELAY	AC SOLID STATE RELAY
REFERENCE	SLD03210-945148	SLA03220-945150
General characteristics		
Operating temperature range	-20 / +80°C	-20 / +80°C
Storage temperature range	-25 / +80°C	-40 / +100°C
Input-Output isolation	2500 VRMS	4000 VRMS
Weight	8g	8g
Conformity	EN60947-5-1	EN60947-5-1
Approved	UL pending	UL pending VDE0805(EN60950)
Control characteristics		
Control voltage	Min:18Vdc Nom:24Vdc Max:32Vdc	Min:18Vdc Nom:24Vdc Max:32Vdc
Control current @ U _c nom	Min:5.5mA Nom:7.7mA Max:10.2mA	Min:5.6mA Nom:7.7mA Max:10.2mA
Release voltage	Max :8.3Vdc	Max :1Vdc
Internal resistance	3000 ohms	3000 ohms
Output characteristics		
Load voltage	Typical : 48Vdc	Typical : 230Vrms
Voltage operating range	0-60Vdc	12-275Vrms
Nominal current	2.5A	2A rms
Non repetitive overload current	6A	80A
On state voltage drop	0.4Vdc @ 2A	1.2V @ I _l nom
Static output On resistance	200 mOhms	
Off State leakage current	< 1mA	< 1.5mA
Minimum load current	1mA	5mA
Turn On time	50 μs	10 μs
Turn Off time	600μs	10ms
Operating switching frequency	10 Hz	47 Hz to 400 Hz (range)
Transient voltage suppressor	Yes	Yes
Peak power dissipation	600W	
Peak voltage (clamping voltage)	60Vdc	600Vac
Synchronizing level		25Vac
Latching voltage		5Vac
Off State Dv / Dt		500V / μs
Max non repetitive Di / Dt max		100A / μs
Snubber		10nF 100ohms

