

## ■ FS-61508-M88

16 channels – termination panel for 8 conditioned safety I/O and 8 direct safety I/O (SIL3)



### Description:

The FS-61508-M88 unit is a remote Termination Panel that can be used in Safety circuit according to IEC 61508 (SIL3), and that allows connecting up to 16 analog or discrete signals. Channel 1 to channel 8 can be conditioned by plugging Safety modules (FS series), and channel 9 to channel 16 are direct channel. It is also possible to use each first 8 channels as direct channel by plugging two jumpers per channel.

### Product options:

Option **ST**: FS-61508-M88-ST: signal connected using Screw Terminals

Option **CCT**: FS-61508-M88-CCT: signal connected using Cage Clamp Terminals or Spring Terminals

### Technical specifications:

#### Dimensions:

Wide : 130 mm  
Length : 195mm  
Depth : 65mm without module  
Depth : 140mm with FS module

#### Weight:

350g without module  
Add 100g per module

#### Mounting:

Asymmetric or symmetric DIN rail

#### Power Supply specifications

Allows redundancy of P.S  
Range: 20Vdc to 28Vdc  
Protection against over voltage by Diode transil and 2,5A fuse (5x20)  
Protection against reverse polarity  
Power ON indicated by green LED  
Consumption without module: 24 mA

#### Temperature range:

Operating: -10°C to 60°C  
Storage: -20°C to 60°C

#### Humidity:

Up to 90% (no condensation)

#### Connection to the SIS:

One SUBD37 pin male connector with UNC 4-40 lock for female connector.

#### Connection to shield:

One M3 screw

#### Connection to 24vdc Power Supply:

One removable 3 contact connector TB1). Conductor section :24 to 12AWG (0.2 to 2.5 mm<sup>2</sup>)

#### Connection to direct I/O:

Termination block TB2 (1A max )  
Terminals TB11 to TB18: (1A max)  
Conductor section 26 to 16 AWG ( 0.14 to 1.5mm<sup>2</sup>)

#### Compatible modules:

DI: FS301A or FS301S  
DO: FS303, FS303-INV or FS304  
AI: FS323

All these modules can be mixed on the Same panel.



SIL3, Bureau Veritas approved.

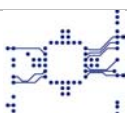
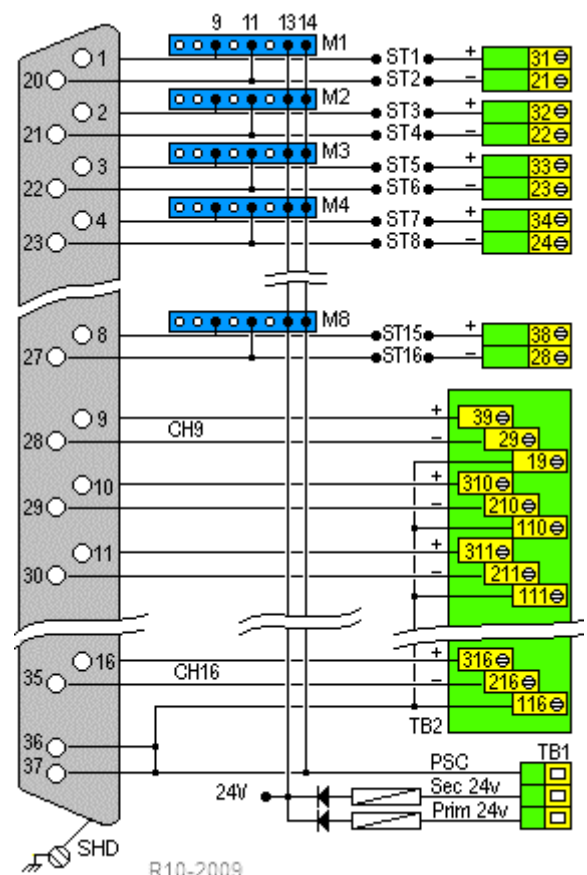

**Wiring connexion:**

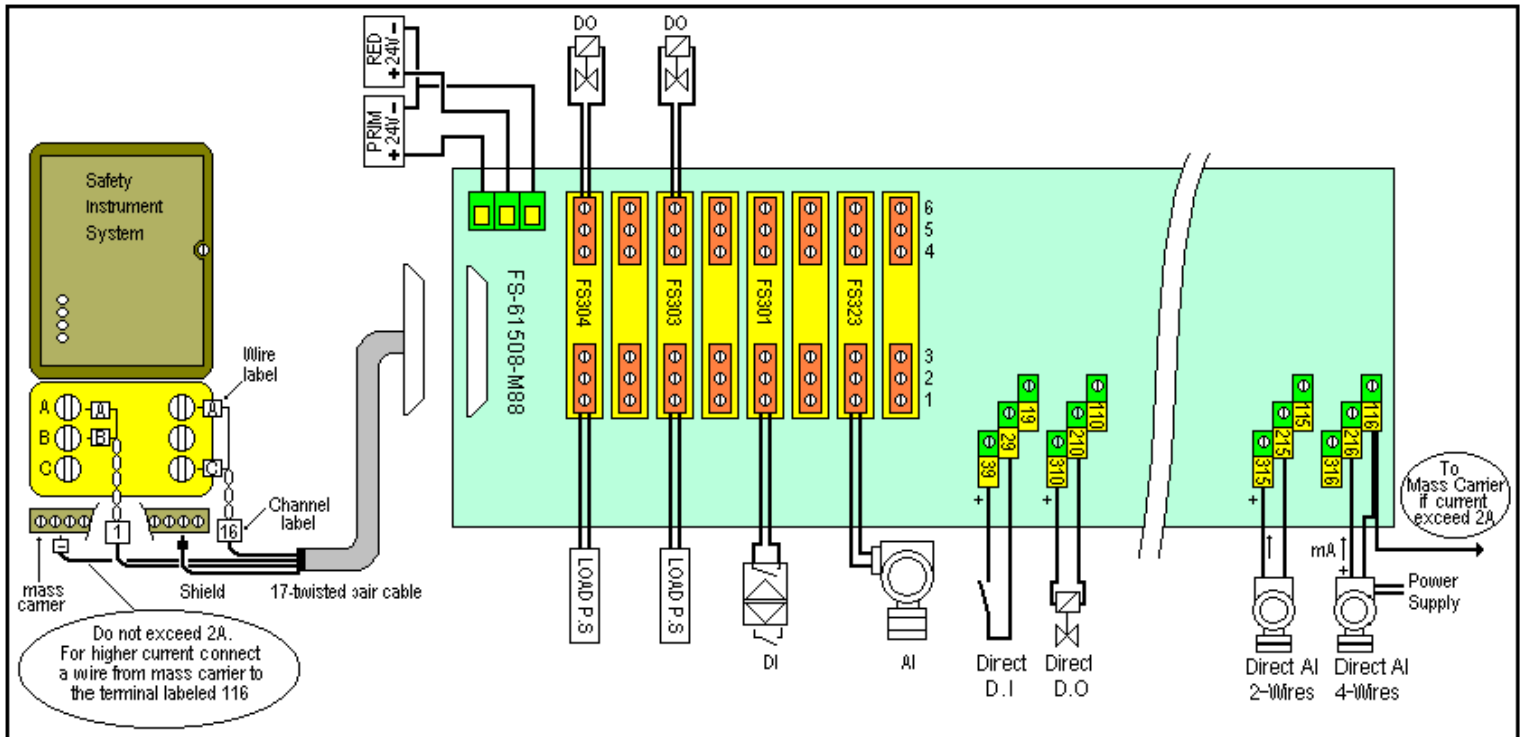

The above figure shows a FS-61508-M88 with eight conditioned DO, DI or AI I/O and eight Direct (no conditioned) I/O.

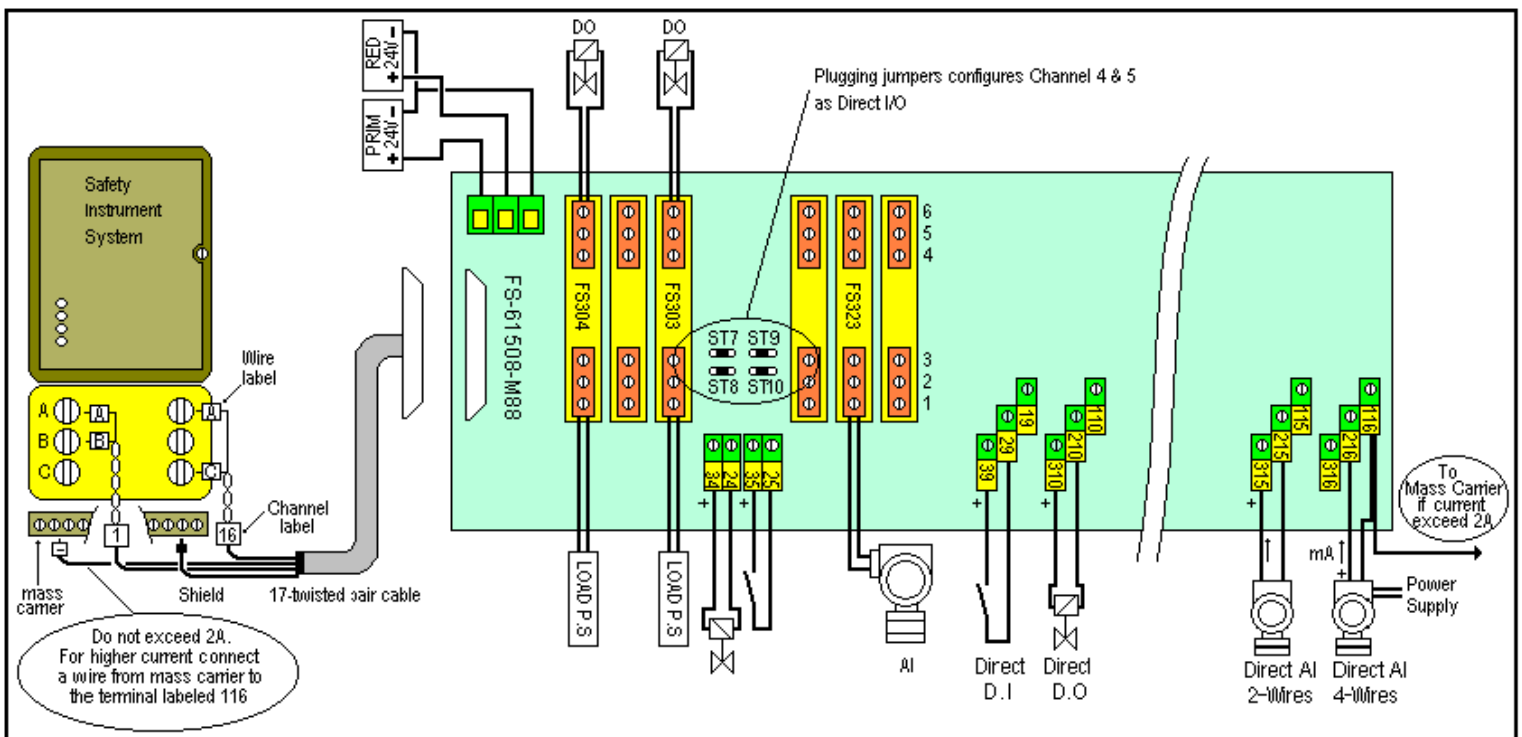

The above figure shows a FS-61508-M88 with six conditioned I/O and ten Direct (no conditioned) I/O. The channel 4 and 5 are configured as Direct I/O, by plugging two jumpers per channel. Four free jumpers are installed on each Termination Panel and are available to do it.

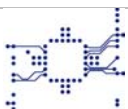

### 1. FIELD WIRING CONNECTION WITH DELTAV SIS, FOR DIRECT D.I.:

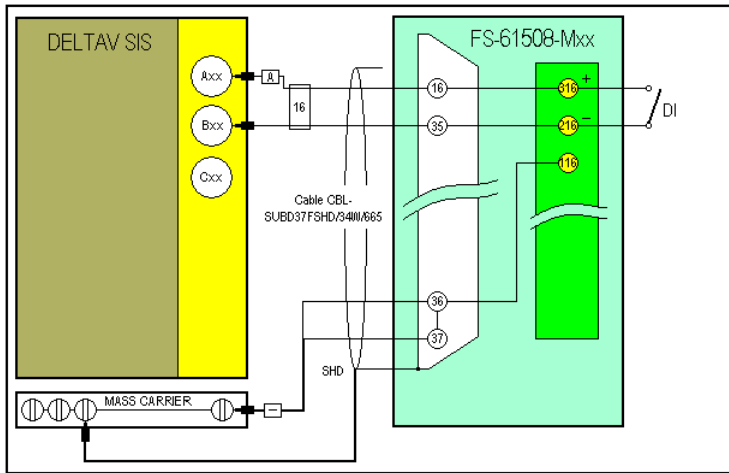

The figure on the left shows the wiring for a Direct Discrete Input connected to channel 16.

The cable from FS-61508-Mxx interface unit is a 17-twisted pair cable. Sixteen twisted pairs (labeled 1 to 16) are used for the 16 channels, and one pair (labeled -) is used to be connected to the mass carrier.

The wire labeled A of each twisted pair is always connected to the terminal A of the DeltaV. The second wire is connected to the B terminal in that case.

### 2. FIELD WIRING CONNECTION WITH DELTAV SIS, FOR DIRECT D.O

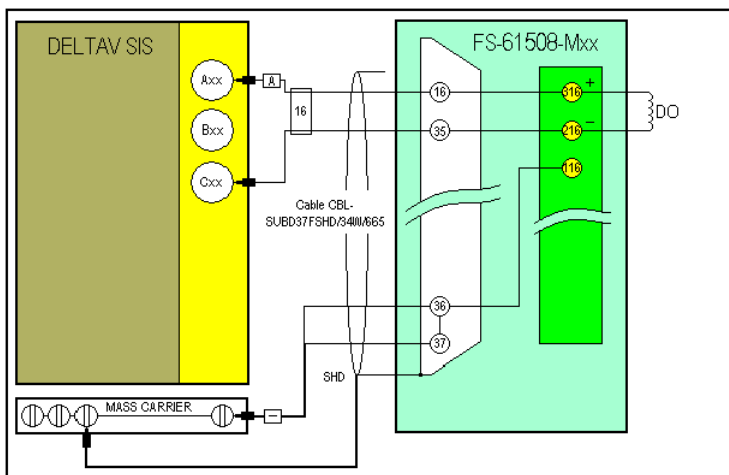

The figure on the left shows the wiring for a Direct Discrete Output connected to channel 16.

The cable from FS-61508-Mxx interface unit is a 17-twisted pair cable. Sixteen twisted pairs (labeled 1 to 16) are used for the 16 channels, and one pair (labeled -) is used to be connected to the mass carrier.

The wire labeled A of each twisted pair is always connected to the terminal A of the DeltaV. The second wire is connected to the C terminal in that case.

### 3. FIELD WIRING CONNECTION WITH DELTAV SIS, FOR DIRECT 2-WIRE A.I.:

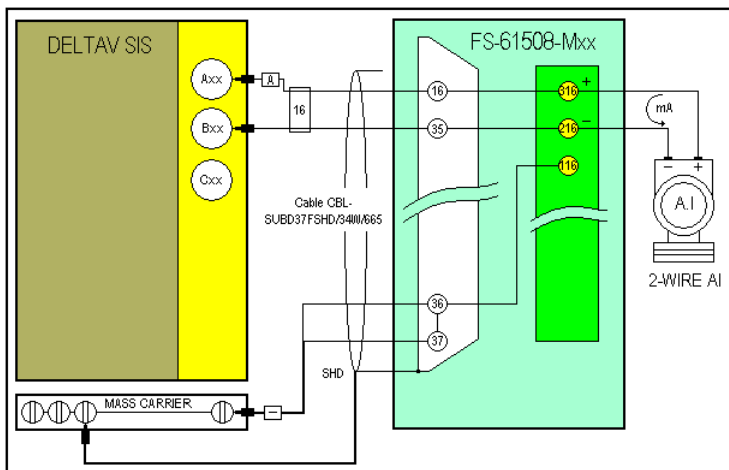

The figure on the left shows the wiring for a Direct 2-wire 4-20mA Analog Input connected to channel 16.

The cable from FS-61508-Mxx interface unit is a 17-twisted pair cable. Sixteen twisted pairs (labeled 1 to 16) are used for the 16 channels, and one pair (labeled -) is used to be connected to the mass carrier.

The wire labeled A of each twisted pair is always connected to the terminal A of the DeltaV. The second wire is connected to the B terminal in that case.

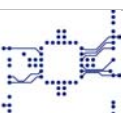

**4. FIELD WIRING CONNECTION WITH DELTAV SIS, FOR DIRECT 3-WIRE A.I.:**

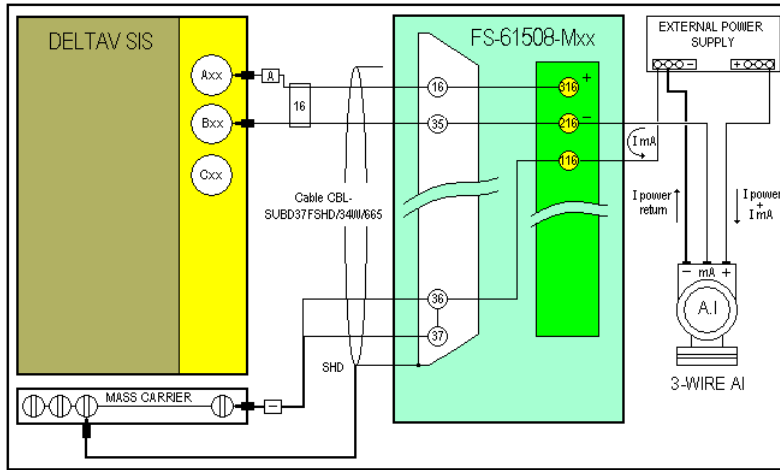

The figure on the left shows the wiring for a Direct 3-wire 4-20mA Analog Input connected to channel 16.

The cable from FS-61508-Mxx interface unit is a 17-twisted pair cable. Sixteen twisted pairs (labeled 1 to 16) are used for the 16 channels, and one pair (labeled -) is used to be connected to the mass carrier.

The wire labeled A of each twisted pair is always connected to the terminal A of the DeltaV. The second wire is connected to the B terminal in that case.

Be careful to follow the recommendation of wiring to avoid high power current in cable.

**5. FIELD WIRING CONNECTION WITH DELTAV SIS, FOR DIRECT 4-WIRE A.I.:**

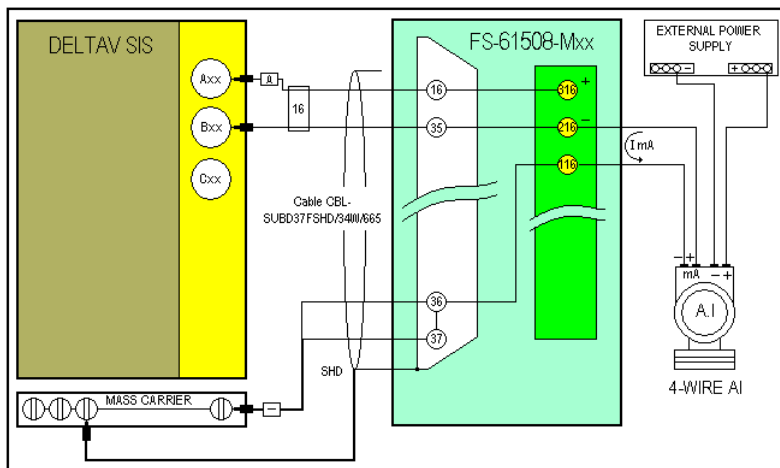

The figure on the left shows the wiring for a Direct 4-wire 4-20mA Analog Input connected to channel 16.

The cable from FS-61508-Mxx interface unit is a 17-twisted pair cable. Sixteen twisted pairs (labeled 1 to 16) are used for the 16 channels, and one pair (labeled -) is used to be connected to the mass carrier.

The wire labeled A of each twisted pair is always connected to the terminal A of the DeltaV. The second wire is connected to the B terminal in that case.

