

■ FS-61508-16

16 channels – termination panel for 16 conditioned safety I/O (SIL3)



Description:

The FS-61508-16 unit is a remote Termination Panel that can be used in Safety circuit according to IEC 61508 (SIL3), and that allows connecting up to 16 analog or discrete signals.

Channel 1 to channel 16 can be conditioned by plugging up to 16 Safety modules (FS series). It is also possible to use each channel as direct channel by plugging two jumpers per channel.

Technical specifications:

Dimensions:

Wide : 130 mm
 Length : 335mm
 Depth : 65mm without module
 Depth : 140mm with FS module

Weight:

500g without module
 Add 100g per module

Mounting:

Asymmetric or symmetric DIN rail

Power Supply specifications

Allows redundancy of P.S
 Range: 20Vdc to 28Vdc
 Protection against over voltage by Diode transil and 2,5A fuse (5x20)
 Protection against reverse polarity
 Power ON indicated by green LED
 Consumption without module: 24 mA

Temperature range:

Operating: -10°C to 60°C
 Storage: -20°C to 60°C

Humidity:

Up to 90% (no condensation)

Connection to the safety system:

One SUBD37 pin male connector with UNC 4-40 lock for female connector.

Connection to shield:

One M3 screw

Connection to 24vdc Power Supply:

One removable 3 contact connector TB1).
 Conductor section: 24 to 12AWG(0.2 to 2.5 mm²)

Connection to direct I/O:

Screw terminals TB11 to TB116
 Conductor section 26 to 16 AWG (0.14 to 1.5mm²). 1A maximum

Compatible modules:

DI: FS301A or FS301S
 DO: FS303, FS303-INV or FS304
 AI: FS323
 All these modules can be mixed on the Same panel.

SIL3, Bureau Veritas approved.

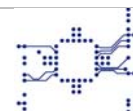
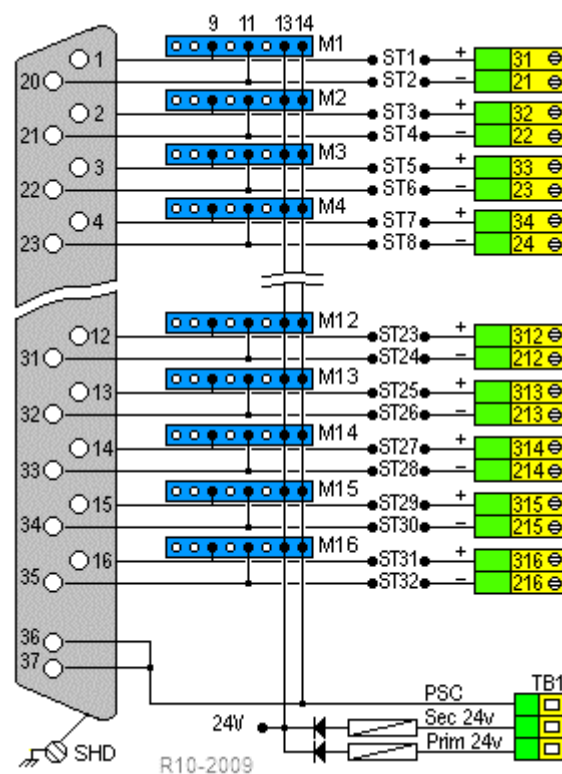

Wiring connexion:

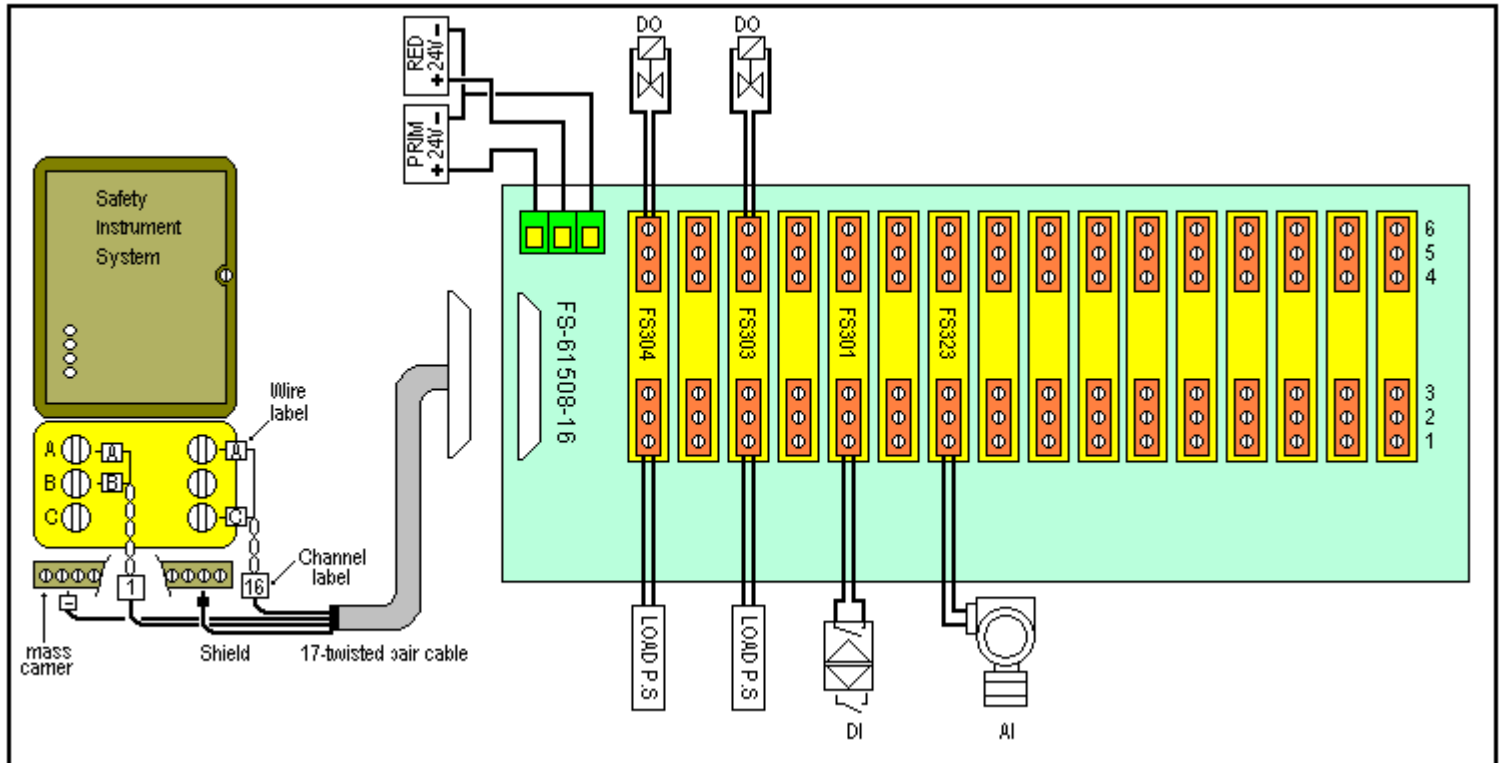

The above figure shows a FS-61508-16 with sixteen conditioned I/O

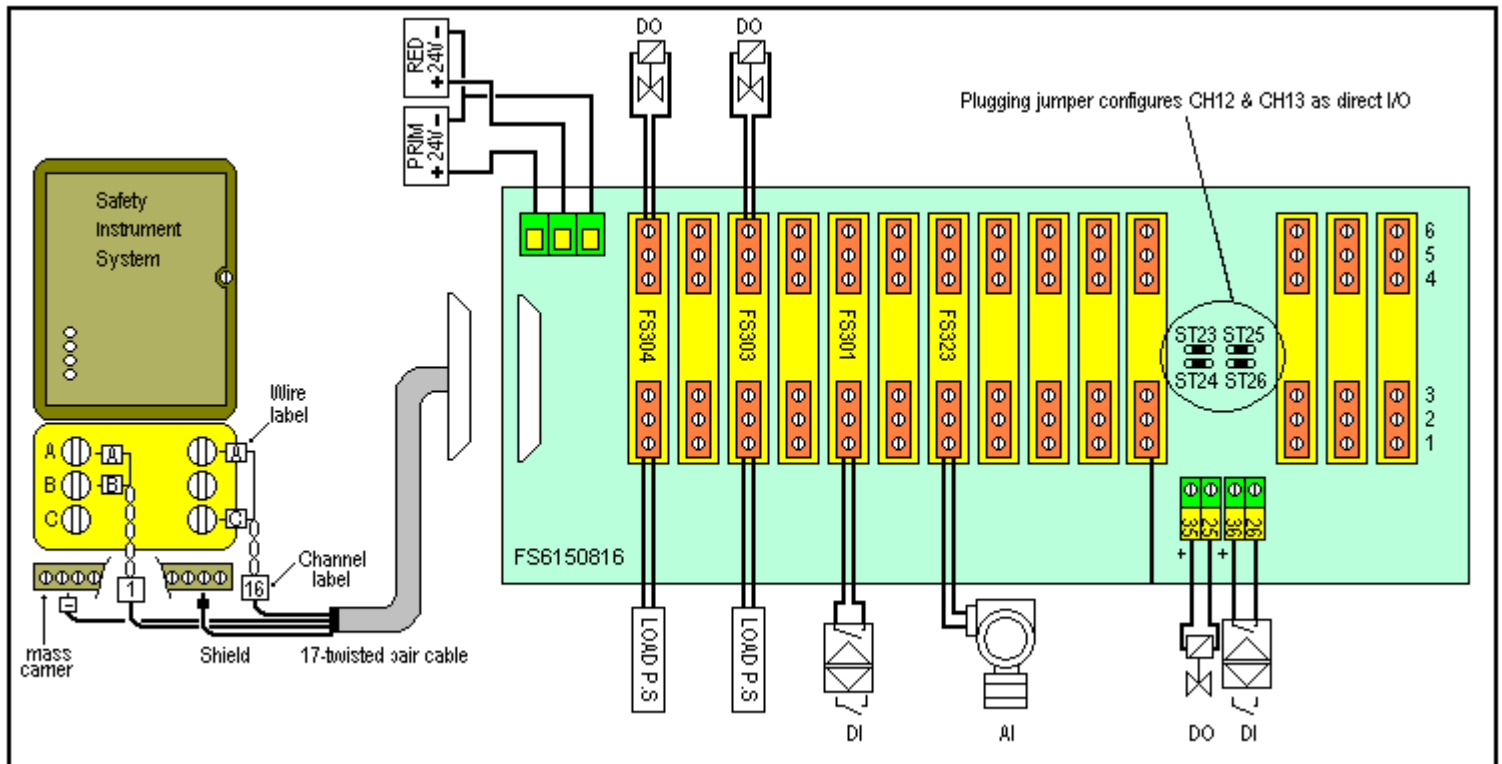

The above figure shows a FS-61508-16 with fourteen conditioned I/O. The channel 12 and 13 are configured as Direct I/O (no conditioned), by plugging two jumpers per channel. Four free jumpers are installed on each Termination Panel and are available to do it.



1. FIELD WIRING CONNECTION WITH DELTAV SIS, FOR DIRECT D.I.:

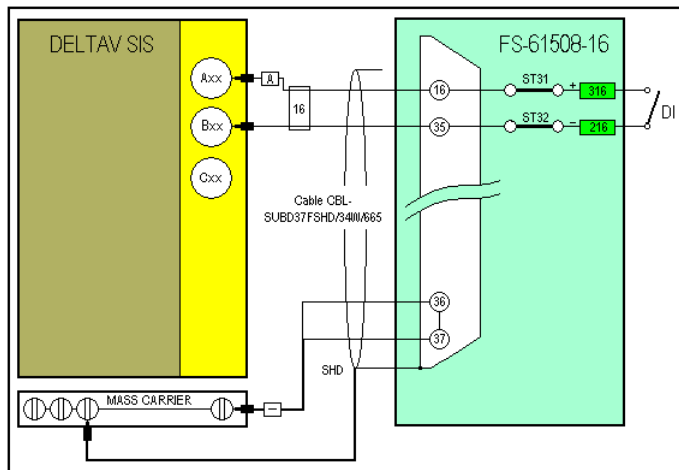

The figure on the left shows the wiring for a Direct Discrete Input connected to channel 16.

The cable from FS-61508-16 interface unit is a 17-twisted pair cable. Sixteen twisted pairs (labeled 1 to 16) are used for the 16 channels, and one pair (labeled -) is used to be connected to the mass carrier.

The wire labeled A of each twisted pair is always connected to the terminal A of the DeltaV. The second wire is connected to the B terminal in that case.

2. FIELD WIRING CONNECTION WITH DELTAV SIS, FOR DIRECT D.O

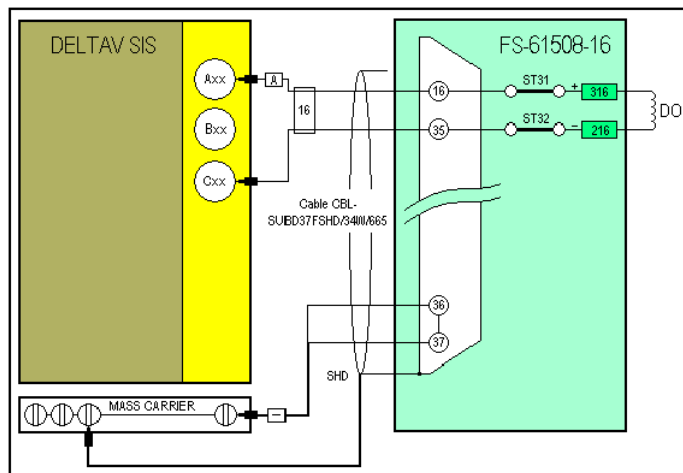

The figure on the left shows the wiring for a Direct Discrete Output connected to channel 16.

The cable from FS-61508-16 interface unit is a 17-twisted pair cable. Sixteen twisted pairs (labeled 1 to 16) are used for the 16 channels, and one pair (labeled -) is used to be connected to the mass carrier.

The wire labeled A of each twisted pair is always connected to the terminal A of the DeltaV. The second wire is connected to the C terminal in that case.

3. FIELD WIRING CONNECTION WITH DELTAV SIS, FOR DIRECT 2-WIRE A.I.:

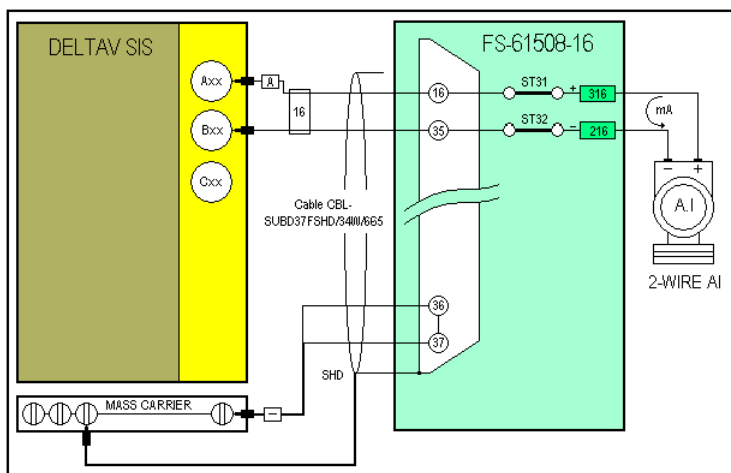

The figure on the left shows the wiring for a Direct 2-wire 4-20mA Analog Input connected to channel 16.

The cable from FS-61508-16 interface unit is a 17-twisted pair cable. Sixteen twisted pairs (labeled 1 to 16) are used for the 16 channels, and one pair (labeled -) is used to be connected to the mass carrier.

The wire labeled A of each twisted pair is always connected to the terminal A of the DeltaV. The second wire is connected to the B terminal in that case.

